

ANSI SERIES

B73-1 2001

INN
PUMPS

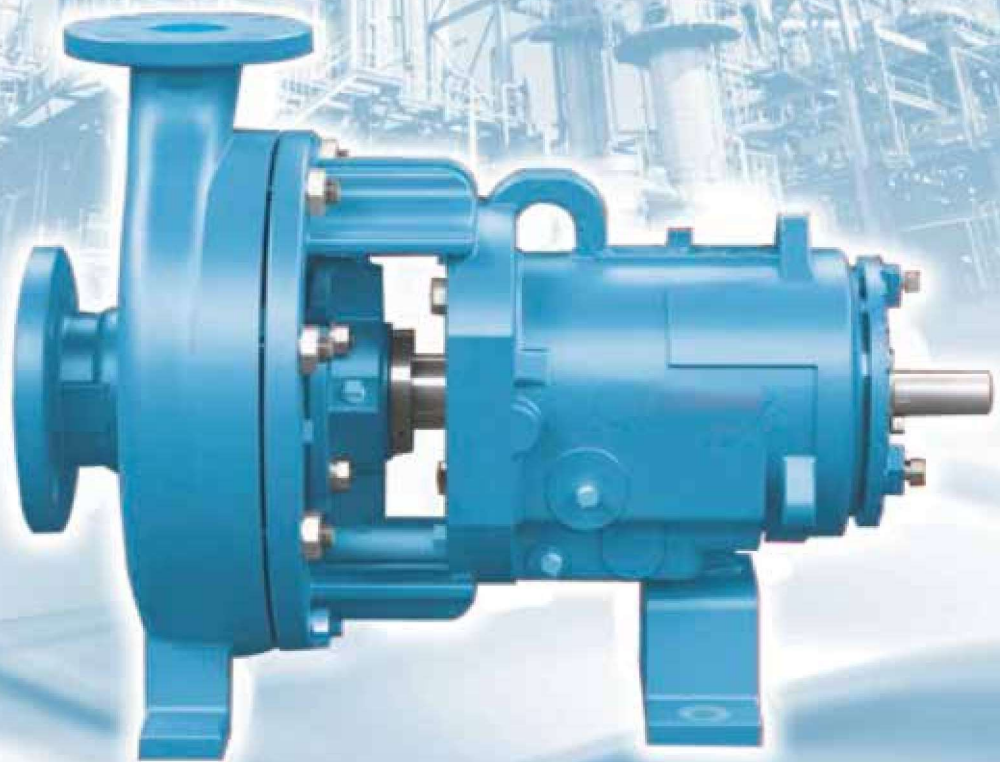

**CENTRIFUGAL CHEMICAL
PROCESS PUMP**

Match - III

DESCRIPTION

RANGE

Delivery Size up to 200 mm (8" Inch)
Capacity up to 410 M³/Hr.
Head up to 150 Meter
Working Pressur 17 kg/Cm²

APPLICATIONS

Acid Transfer, Beverage Processing, Brine, Chemical Processing, Chloral-alkali, Corrosive Services, Organic Chemicals, Polymers, Sea Water, Solvents, Paper, Food, Synthetic Fibers, Slurry & others.

CONSTRUCTIONAL FEATURES

Pumps are as per ANSI B73.1-2001. The design is of back pull out type. Large varieties of models are available to operate at 1450 RPM and 2900 RPM at 50 HZ & 1750 RPM and 3500 RPM at 60 HZ. ANSI series chemical process pump is a horizontal single stage centrifugal pump.

SHAFT

The shaft is of the dry type, with protection sleeve to prevent contact with the pumped liquid (for gland packed & standard mechanical seal only). For specialized cartridge mechanical seal models the shaft will be in contact with the pumped liquid.

SHAFT SEALING

The stuffing box is sealed by gland packing or by mechanical seal. Conversion from gland packing to mechanical seal is achieved by changing some standardize parts. Re-machining of stuffing box is not necessary. Stuffing box cooling is provided for high temperature applications

BEARINGS

The bearing arrangement consists of Double Row Angular Contact Ball Bearing and Single Row Deep Groove Ball Bearing. Oil level indicator is provided for oil level checking and maintaining.

Pump rotating element can be withdrawn towards the Motor end without disturbing the suction or delivery pipe lines, due to back pull out design. The motor remain fixed to base plate. The pump rotating element can easily be dismantled in to its components. After reassembly no time consuming re-alignment is necessary.

CASING

The casing has end suction and top centre line delivery. The pump feet are integrally cast in the volute casing. Smooth hydraulic passages ensure high efficiency.

IMPELLER

Impellers are of open type. Hydraulic balancing of impellers is achieved either by back vanes or by balancing holes. The impellers are dynamically balanced. Reliable fixing of the impeller on shaft is achieved by using helicoil insert under impeller nut.

DIRECTION OF ROTATION

Clockwise viewed from driving end

DRIVE

The pump is only recommended for direct via a flexible spacer coupling. Spacer couplings enable utilization of the back pull out feature.

BASE PLATE

Base plates for electric drives are available in a variety of styles.
Standard: Fixed & grouted directly to the foundation
Anti Vibration: Rigid base plate on rubber mounts

FLANGES

Standard	Optional
ANSI B16.5 - 150 Class	Available on request



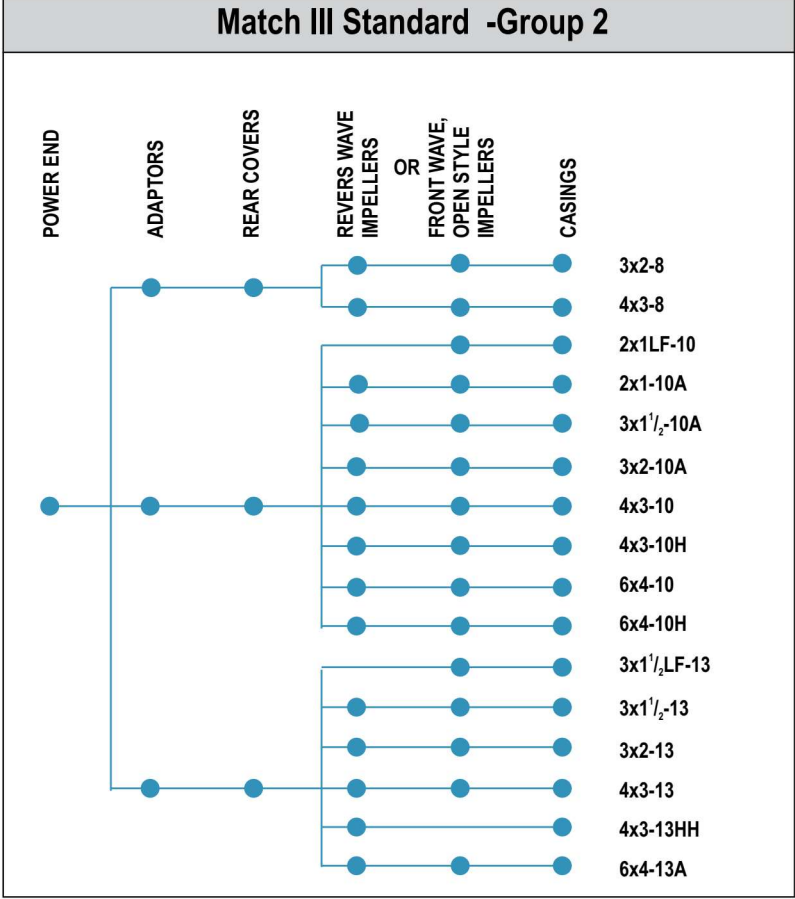
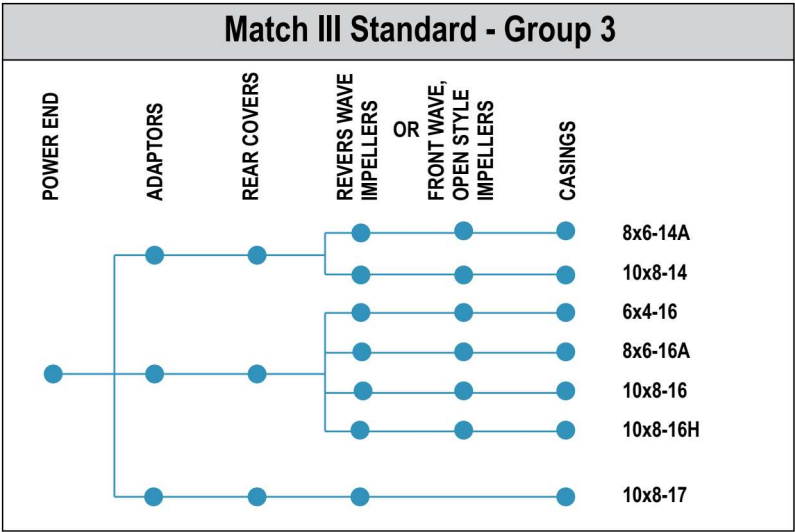
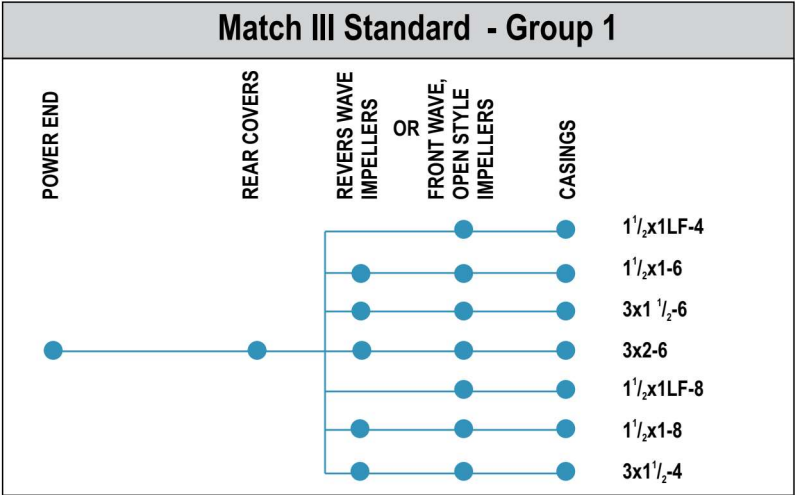

REVERSE VANE IMPELLER DESIGN

Smoothflo offers pumps with reverse vane impeller which provides high efficiency and performance. The reverse vane design increases the bearings and seal life and thus offers low cost of the pump maintenance.

- ❖ Required NPSH is low compared to standard centrifugal process pumps.
- ❖ Back Pull-out design allows removal of rotating parts without removing casing, piping or motor.
- ❖ Due to reverse vane impeller low pressure on the seal chamber results in long life of seal.
- ❖ Rear cover plate wear surface rather than the casing which is expensive. Flow exits from the rear of the impeller hence abrasive wear on the rear cover.

OPEN IMPELLER (FRONT VANE)

- ❖ **SmoothFlo** also offers the pump with open type impellers.
- ❖ It has complete interchangeability with reverse vane impellers.
- ❖ These type of impellers are mostly used in the applications where liquid contains solid particles or fibrous.



SECTION DRAWING FOR MATCH-III GROUP - 1

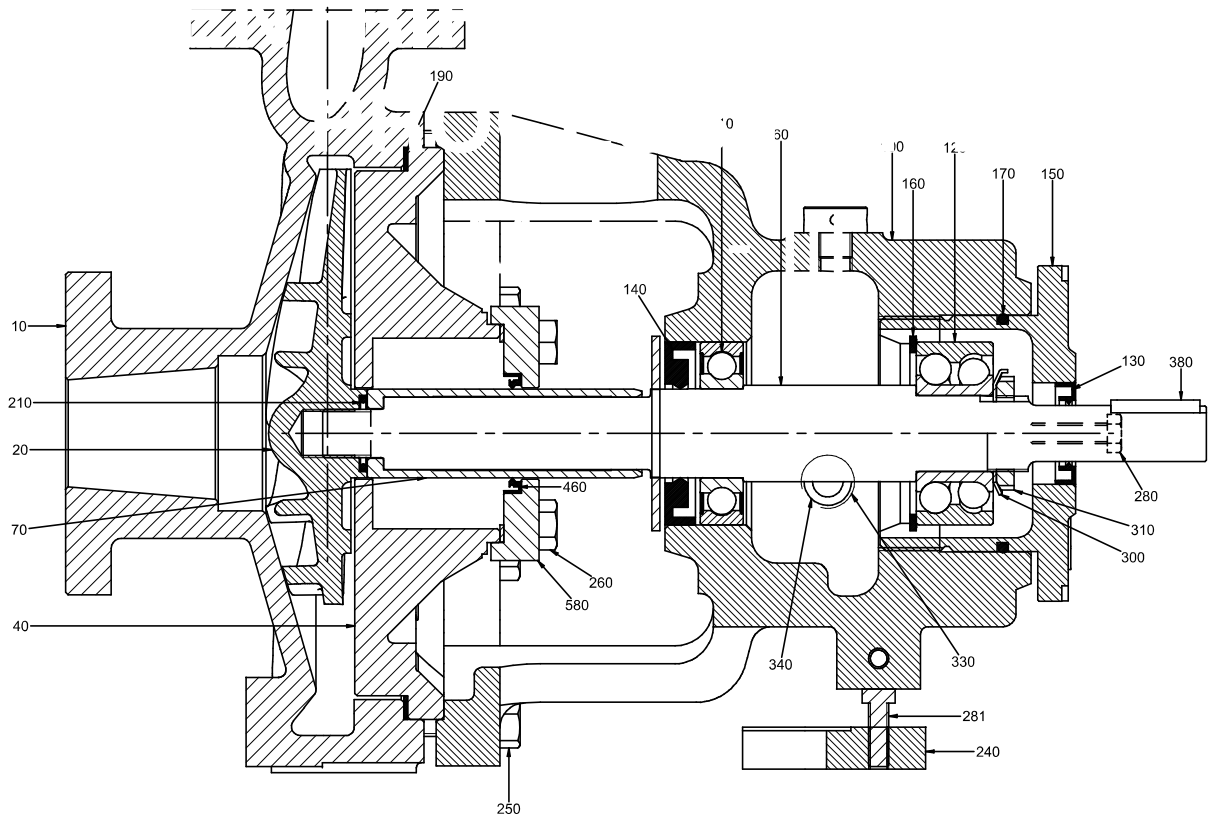

SECTION DRAWING FOR MATCH-III GROUP - 2 & 3

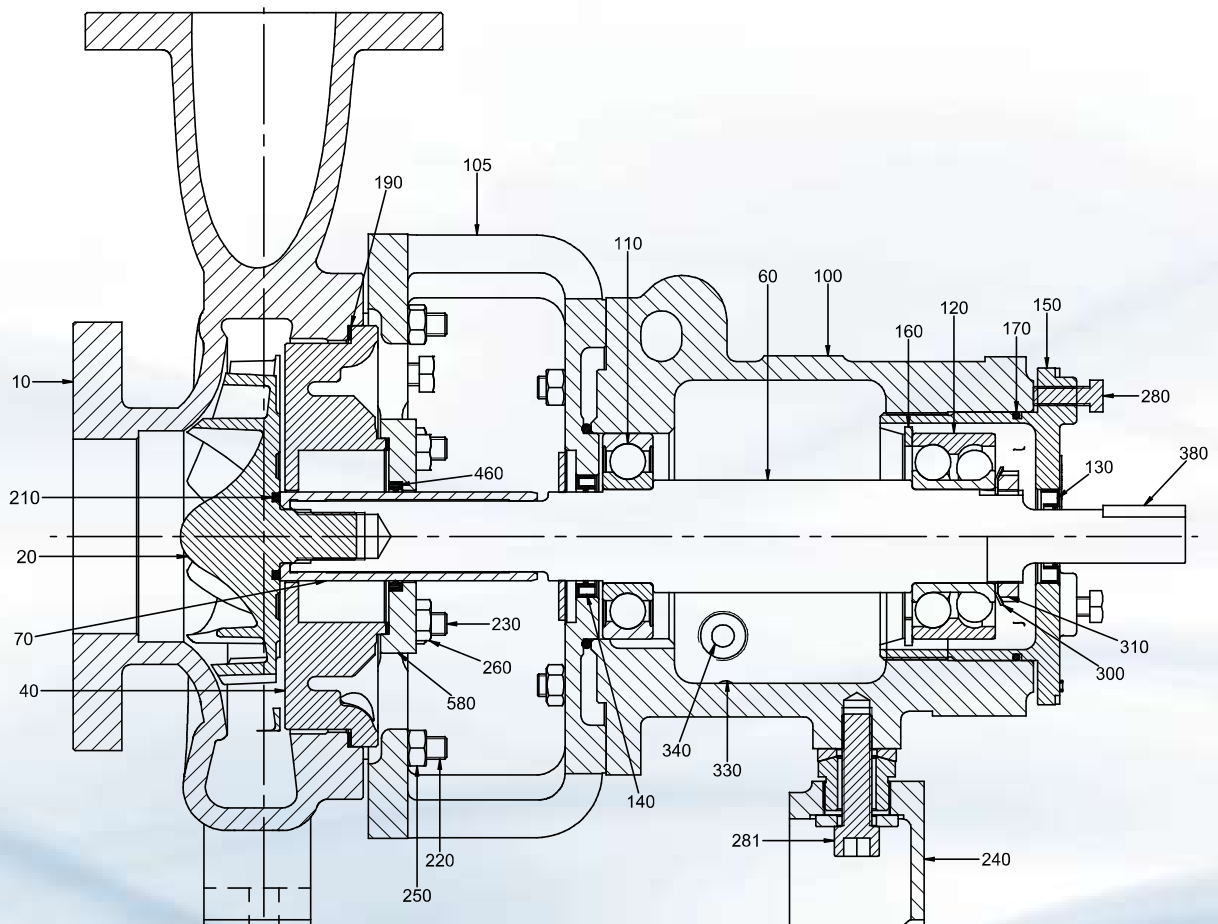

BILL OF MATERIAL FOR SOFT PACKED PUMP

Pos. No.	Qty.	Description	Material						
			CI	CS	CF8	CF8M	A 20	HC	HB
10	1	Volute casing	CI	CS	CF8	CF8M	A 20	HC	HB
20 *	1	Impeller	CI	CS	CF8	CF8M	A 20	HC	HB
40	1	Stuffing Box	CI	CS	CF8	CF8M	A 20	HC	HB
60	1	Shaft	SS 410		SS304	SS316			
70	1	Shaft Sleeve	SS410		SS304	SS316	A20	HC	HB
100	1	Bearing housing	CI						
105	1	Lantern Piece	CI						
110 *	1	Ball Bearing	Steel						
120 *		Ball Bearing	Steel						
130 *	1	Oil Seal – Drive End	Nitrile						
140 *	1	Oil seal - Non Drive End	Steel			Nitrile	SS304		
150	1	Adjusting Bush	Steel			CI	SS304		
160	1	Internal circlip	Steel				CI		
170 *	1	O Ring	Steel			Nitrile	SS304		
190 *	1	Gasket - volute casing	Steel			PTFE	SS304		
210 *	1	Gasket - Shaft Sleeve	PTFE						
220	x	Stud for volute casing							
230	x	Stud for Stuffing box							
240	1	Support Foot							
250	x	Hex nut for volute casing							
260	x	Hex nut for Stuffing box							
280	x	Bolt for Adjusting Bush	Steel						
281	1	Bolt for support foot	Steel						
300	1	Lock nut washer	Steel						
310	1	Lock Nut	Steel						
330	1	Plug	Steel						
340	1	Oil Level Indicator	Aluminum						
380	1	Key at drive end	Steel						
460 *	1	Oil Seal at gland plate	Nitrile						
580	1	Gland Plate	Steel	SS304	SS316	A20	HC	HB	

* - Recommended Spares x – Quantity depends on model

HYDRAULIC COVERAGE

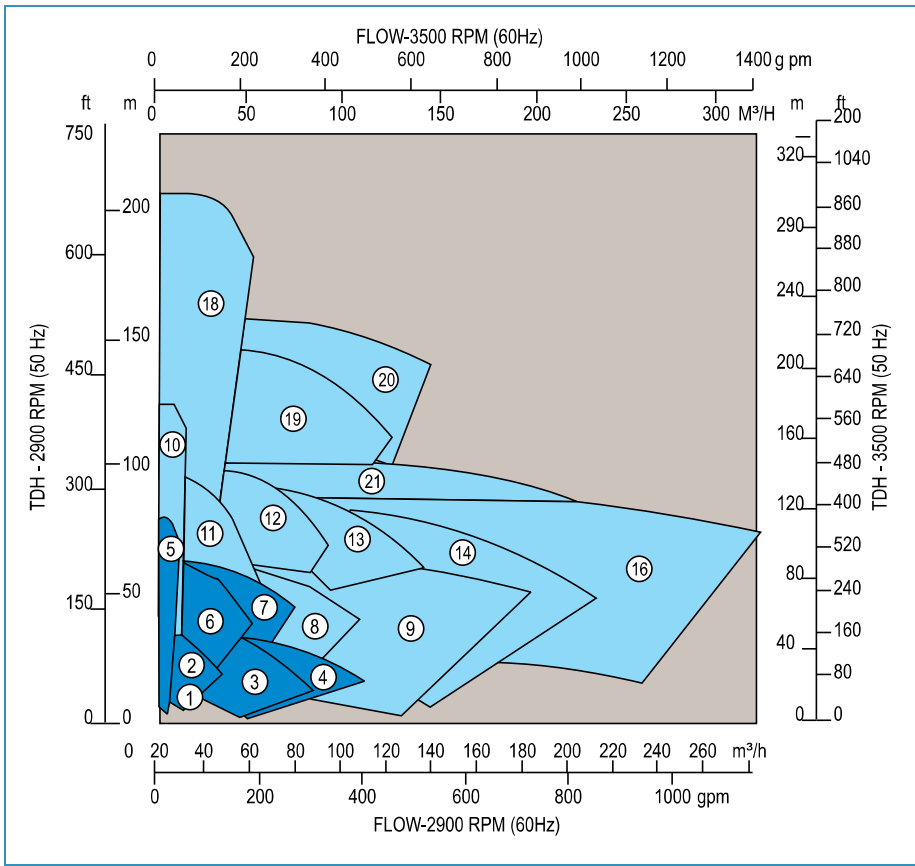

Match III Standard Group 1	Match III Standard Group 3
1 1½x1LF-4	24 8x6-14A
2 1½x1-6	25 10x8-14
3 3x1 ½-6	26 6x4-16
4 3x2-6	27 8x6-16A
5 1½x1LF-8	28 10x8-16
6 1½x1-8	29 10x8-16H
7 3x1 ½-8	30 10x8-17³
Match III Standard Group 2	
8 3x2-8	
9 4x3-8	
10 2x1LF-10	
11 2x1-10A	
12 3x1 ½-10A	
13 3x2-10A	
14 4x3-10	
15 4x3-10H	
16 6x4-10	
17 6x4-10H	
18 3x1 ½LF-13	
19 3x1 ½-13	
20 3x2-13	
21 4x3-13	
22 4x3-13HH	
23 6x4-13A	

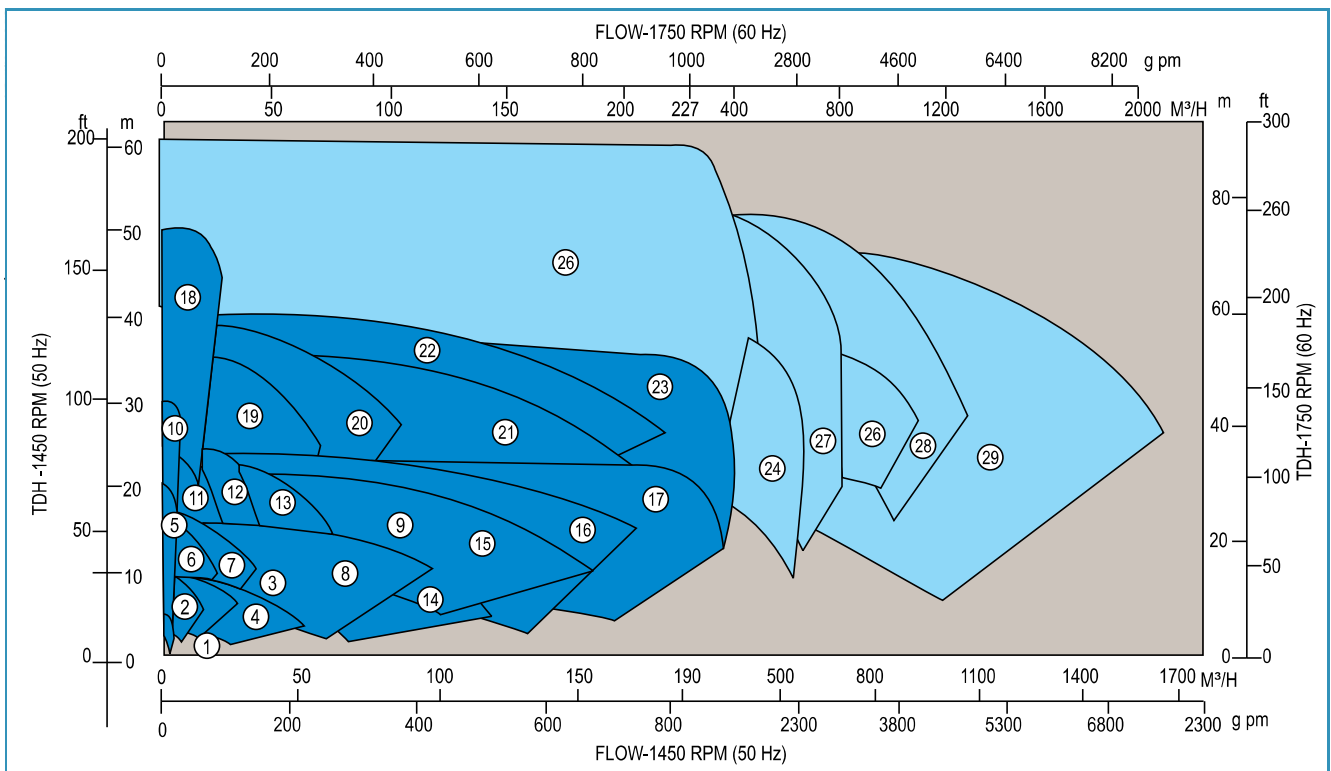

Inno Engineered Products Pte Ltd

48 Siglap Drive, Singapore 456173

Tel: (65) 6441 3455 | Fax: (65) 6441 5677

Website: www.smoothflopumps.com.sg

